



Phone: 0769—82960405 Website: <http://www.jiabaida.com>

Address: 2nd Floor, Building 6, No. 40, Baoyuan 2nd Road, Lianhu, Tangxia Town, Dongguan City Alibaba:
<http://jiabaida.1688.com>

Product Confirmation

client's name		Customer Type	JBD-AP20S003S-L20S-200A-B-C
Our material number		Customer Part Number	
Delivery date	2020-11-5	Company model	JBD-AP20S003S
Edition	A02	Number of pages	7

Approved	Audit	Draw up
		Wang Ligang

material code	JBD-AP20S003S-L20S-200A-B-C
---------------	-----------------------------

Customer Confirmation Column

Confirmation:

signature:

date:

Special Note:

1. After the customer receives the sample, please organize the test in time and feed back the test result to our company to facilitate our company to arrange the follow-up work of this project. If there is no reply within 5 days, the company defaults to the customer's test passing.

JBD-AP20S003	Specification: Protection circuit module	
	Page:2 Total:13	Date:12/17/2021

The project ends normally.

2. If the customer passed the test, please specify the product name and product code in the customer comment column, and stamp and sign for confirmation. Otherwise, please point out the problem in the unqualified column and make suggestions for improvement.

3. Our company can only receive orders after receiving the original signed and sealed by the customer and attaching the detailed function description of the product description.

one, Introduction and features

JBD-AP20S003S is an intelligent protection board solution designed by Dongguan Jiabaida Electronic Technology Co., Ltd. for 7-20 series battery packs of power batteries, electric bicycles, electric motorcycles, etc.; it can be applied to lithium batteries with different chemical properties, such as lithium ion, lithium polymer, lithium iron phosphate, etc. The protection board has strong loading capacity, and the maximum continuous discharge current can reach 200A.

- 7~20 battery cells are protected in series, and the number of battery strings is automatically recognized.

- Vehicle-grade analog front-end chip, high voltage acquisition accuracy, safer and more reliable.

- Various protection functions for charging and discharging

- The power switch is a relay with high withstand voltage and more reliability.

- Accurate SOC calculation, with automatic learning SOC function

- Bluetooth communication function.

- Optional RS485 communication function, can read all the battery data in real time, and online upgrade.

- Support CAN communication function

- A reserved switch controls the output of the protection board. With the discharge switch, the pre-charge function is available to prevent lighting.

- When the standing time reaches the set value (parameter setting page switch time), it will automatically shut down and sleep, reducing standby power consumption.

- Supports the use of battery packs in series, but the total number of strings after series connection is less than or equal to 32 strings.

- Parallel use of battery packs is not supported (battery packs are directly connected in parallel, and there is a problem of large current discharge from high-voltage battery packs to low-voltage battery packs).

Second, the principle block diagram

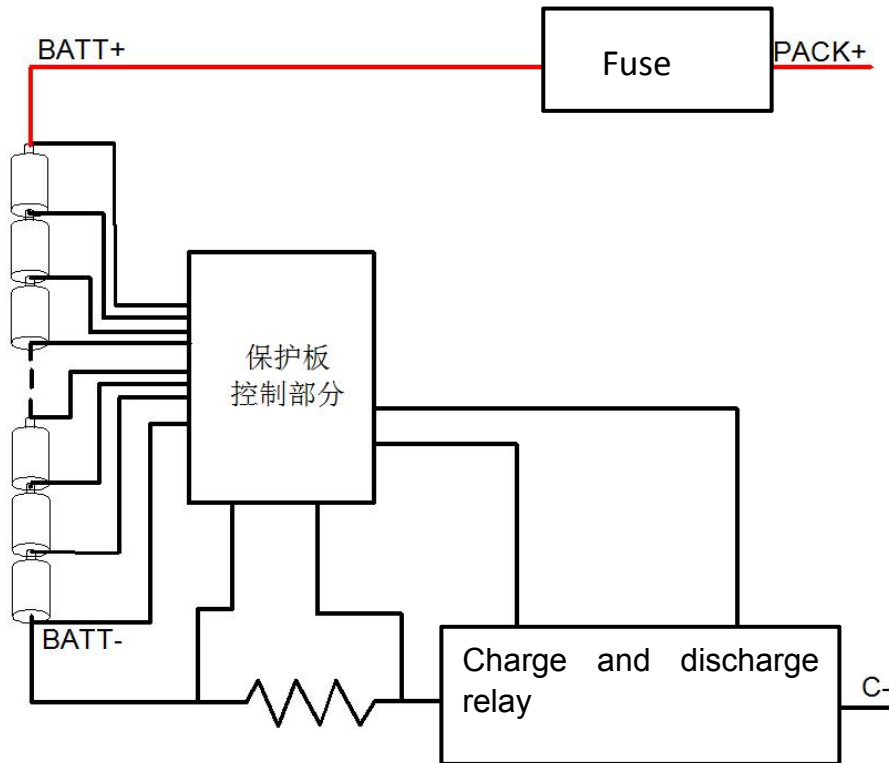

Three, the basic parameters

3.1 The scope of use:

- Battery pack structure: 20S
- charging method: CC-CV(Constant current and constant voltage)
- Discharge method: Constant current discharge
- Output terminal: C-;
- Input terminal: B-, BC0~BC20

3.2 Electrical parameters (The test needs to be performed indoors at a temperature of 25±2°C and a relative humidity of 65+/-20%.)

Function	Test items	Specification			unit
		Minimum	Typical value	Max	
Operating Voltage	voltage range	50		73	V
Working current	Charging current (continuous)			200	A
	Discharge current (continuous)			200	A
Charging protection	Charger voltage (CC-CV)	73			V
	Overcharge protection voltage	3.600	3.650	3.700	V
	Overcharge protection delay time	1000	2000	3000	mS
	Overcharge protection recovery voltage	3.400	3.450	3.500	V
Discharge protection	Over discharge protection voltage	2.400	2.500	2.600	V

JBD-AP20S003	Specification: Protection circuit module				
	Page:4 Total:13		Date:12/17/2021		
	Over-discharge protection delay time	1000	2000	3000	mS
	Over-discharge protection recovery voltage	2.900	3.000	3.100	V
Overcurrent protection	Charging overcurrent protection value	270	300	330	A
	Charge overcurrent delay	8	10	12	S
	Charge overcurrent release recovery conditions	Delay 32S release			
	Discharge overcurrent 1 protection current value	270	300	330	A
	Discharge overcurrent 1 protection delay	8	10	12	S
	Discharge overcurrent 2 protection current value	800	1000	1200	A
	Discharge overcurrent 2 protection delay	600	1200	1800	mS
	Discharge overcurrent protection recovery conditions	Delay 32S release			
	Short circuit protection	Short circuit protection delay time		5000	
Short circuit protection recovery		Disconnect the load and release with a delay of 60S.			
Balance function	Balanced opening voltage	3.320	3.350	3.380	V
	Balanced opening pressure difference		10		mV
	Balanced mode	Charge/discharge/static balance			
	Balance current	100	180	260	mA
Temperature protection	Charging high temperature protection value	62	65	68	° C
	Charging high temperature protection release value	52	55	58	° C
	Charging low temperature protection value	-8	-5	-2	° C
	Charging low temperature protection release value	-3	0	3	° C
	Discharge high temperature protection value	72	75	78	° C

	Discharge high temperature protection release value	62	65	68	° C
	Discharge low temperature protection value	-25	-20	-15	° C
	Discharge low temperature protection release value	-15	-10	-5	° C
Internal resistance	Internal resistance of discharge circuit	/	5	10	mR
Self-consumption	Working mode (relay closed)		35	50	mA
	Sleep mode			500	uA
	Sleep conditions and delay	Delay 65000S in the state of no current/communication/protection (can be set)			
Operating temperature	Normal working range	-20		70	° C
storage temperature	The humidity is below 90%,	-40		85	° C
Protection board with shell size	length Width Height	165*114.5*76 (±2)			mm

3.3 Software parameter description:



3.4 Protection function description:

Overcharge protection: When the battery is charging, the voltage continues to rise. When the protection board detects that the voltage of any cell is higher than the overcharge protection value, the protection board immediately starts timing. When the time reaches the overcharge

JBD-AP20S003	Specification: Protection circuit module	
	Page:6 Total:13	Date:12/17/2021

protection delay, the protection board turns off The charging and discharging relay, the charging is cut off, it cannot be charged at this time.

Overcharge protection recovery: After the overvoltage protection of the protection board occurs, the battery voltage drops when the battery is standing or discharged. When the protection board detects that the voltage of each cell is lower than the overcharge protection recovery voltage, the protection board outputs a signal and turns on the charge and discharge relay. It can be charged at this time.

Over discharge protection: When the battery is in the discharging state, the voltage keeps decreasing. When the protection board detects that the voltage of any cell is lower than the over-discharge protection value, the protection board immediately starts timing. When the time reaches the over-discharge protection delay, the protection board output signal turns off. The charge and discharge relay is turned off, the discharge is cut off, and the load lock circuit works, and it cannot discharge at this time.

Over-discharge protection recovery: After the protection board has over-discharge protection, the battery voltage will continue to rise when the battery is standing or discharged. When the protection board detects that the voltage of each cell is higher than the over-discharge protection recovery voltage, the protection board outputs a signal and turns on the charge and discharge relay , It can be discharged at this time.

Overcurrent protection: When the protection board detects that the current reaches the overcurrent protection value, the protection board starts timing, When the current duration in the loop reachesAfter the overcurrent protection delay time, the output signal of the protection board is turned off,**Charge and discharge relay**, Can't discharge at this time.

Overcurrent protection recovery: After the discharge overcurrent protection occurs on the protection board, the delay reaches the set overcurrent release time, the protection board outputs a signal, and the charging and discharging relay is turned on, and the discharge can be done at this time.

Note: If the parameters of the protection board have been adjusted, please read the internal parameters of the protection board before making changes. After the modification is completed, click Write. If the nominal capacity of the battery pack has not been notified to our company, please change it after communication.

Fourth, the numbering details:

JBD – AP20S003S – L20S – 200A – B – C

(1) (2) (3) (4) (5) (6)

- (1) Jiabaida Electronic Technology Co., Ltd. Abbreviation: JBD
- (2) Our protection board model: AP20S003S, supports up to 20 strings.
- (3) L20S is the sample delivered this time as a sticker; 20 series protection boards for iron-lithium batteries.

JBD-AP20S003	Specification: Protection circuit module	
	Page:7 Total:13	Date:12/17/2021

(4) If the maximum charge and discharge current exceeds this current, the protection board may be permanently damaged.

(5) With equalization function.

(6) With CAN communication function.

After your company receives the specifications and samples, the verification test is completed. If you need subsequent batches, please sign this specification and return this specification to our company, and our company will send it to your company according to the specifications of this specification. batch.

This specification defines Dongguan Jiabaida Electronic Technology Co., Ltd.(Hereinafter referred to as "My company") According to the design requirements provided by your company, design and manufacture the functions, electrical parameters, mechanical parameters, packaging, transportation, and installation methods of the lithium battery pack management system. After confirmation by your company, this specification is only for our company and your company's internal use, and cannot be given to third parties without our permission, and our company has the final right to interpret this specification.

Five, PCB trace and size structure diagram

Top-level wiring diagram

Bottom wiring diagram

PCB size drawing (PCB size 97*114.5*1.6mm)

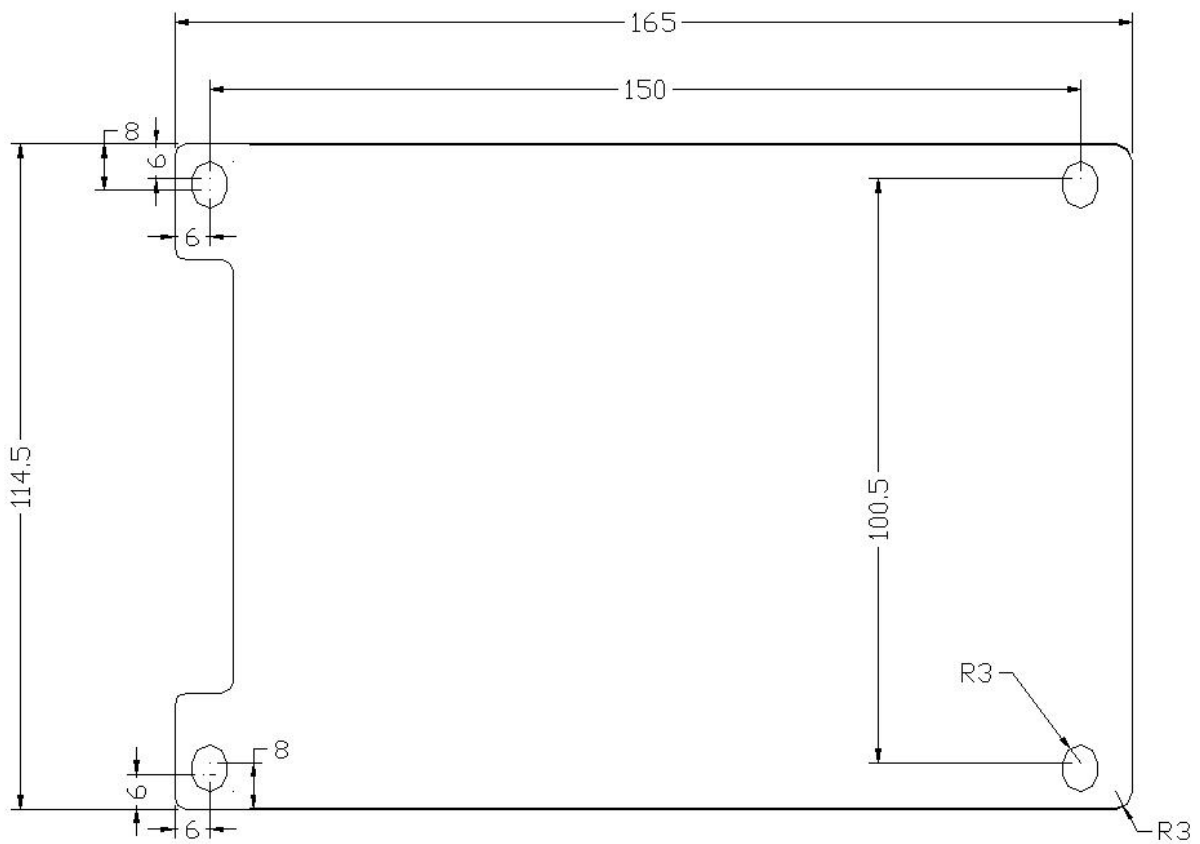

Installation dimension drawing

六、Wiring diagram

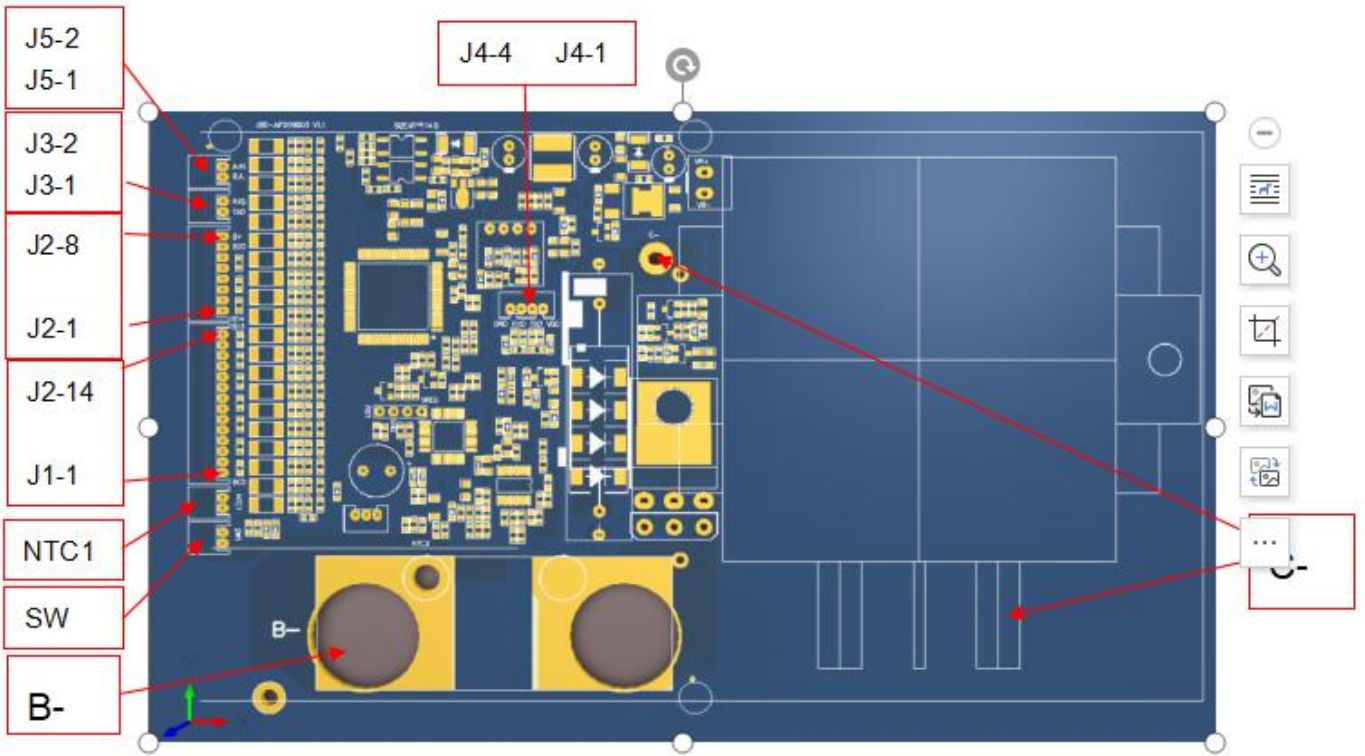

port	instruction
C-	Charge and discharge negative electrode
B-	Connect the negative pole of the first string of the battery pack, that is, the total negative pole of the battery pack

JBD-AP20S003		Specification: Protection circuit module	
		Page:10 Total:13	Date:12/17/2021
J1	1	Connect to the negative pole of the first string of the battery pack	
	2	Connect the first string of the battery pack to the positive pole	
	3	Connect the second string of the battery pack to the positive pole	
	4	Connect to the positive pole of the third string of the battery pack	
	5	Connect the 4th string of the battery pack to the positive pole	
	6	Connect to the positive pole of the fifth string of the battery pack	
	7	Connect the 6th string of the battery pack to the positive pole	
	8	Connect to the positive pole of the seventh string of the battery pack	
	9	Connect to the positive pole of the 8th string of the battery pack	
	10	Connect to the positive pole of the 9th string of the battery pack	
	11	Connect to the positive pole of the 10th string of the battery pack	
	12	Connect to the positive pole of the 11th string of the battery pack	
	13	Connect the 12th string of the battery pack to the positive pole	
	14	Connect the battery pack to the 13th string positive	
J2	15	Connect to the positive pole of the 14th string of the battery pack	
	16	Connect to the positive pole of the 15th string of the battery pack	
	17	Connect to the positive pole of the 16th string of the battery pack	
	18	Connect to the positive pole of the 17th string of the battery pack	
	19	Connect the battery pack to the 18th string positive	
	20	Connect the positive pole of the 19th string of the battery pack	
	21	Connect to the positive pole of the 20th string of the battery pack (voltage acquisition)	
	22	Connect to the positive pole of the 20th string of the battery pack (BMS power supply)	
J3	1	RXD	
	2	TXD	
J5	1	CAN-L	
	2	CAN-H	
J4 Built-in Bluetooth interface	1	VDD (for GND level 11V Bluetooth power supply, not connected at other times.)	
	2	TXD2	
	3	RXD2	
	4	GND	
NTC1		External temperature probe	

Automatically identify the connection method of the number of strings

20S	Not shorted	
19S	BC17~BC18 are shorted, and 17 series of positive poles are connected together	
18S	BC16~BC18 are shorted, and 16 series of positive poles are connected together	
17S	BC15~BC18 are shorted, and 15 series of positive poles are connected together	
16S	BC14~BC18 are shorted, and 14 series of positive poles are connected together	
15S	BC13~BC18 are shorted, and 13 series of positive poles are connected together	
14S	BC12~BC18 are shorted, and 12 series of positive poles are connected together	
13S	BC11~BC18 are shorted, and 11 series of positive poles are connected together	
12S	BC10~BC18 are shorted, and 10 series of positive poles are connected together	
11S	BC9~BC18 are shorted, and 9 series of positive poles are connected together	
10S	BC8~BC18 are shorted, and 8 series of positive poles are connected together	
9S	BC7~BC18 are shorted, and 7 series of positive poles are connected together	
8S	BC6~BC18 are shorted, and 6 series of positive poles are connected together	
7S	BC5~BC18 are shorted, and 5 series of positive poles are connected together	

seven , Wiring sequence

When assembling the wiring, correctly weld the flat cable to the battery cell, connect the B- of the PCM to the main negative pole of the battery, and then insert the flat cable into the pin seat on the PCM.

(Note: The wiring method is different for different string numbers, and the same port split-port wiring method is also different).

Nine, use matters needing attention

1. During use, the design parameters and use conditions must be followed, and the parameters

- of this specification must not be violated, otherwise the protection board will be easily damaged and the battery pack will be damaged.
2. Prevent static electricity during use, and take corresponding measures to discharge static electricity when testing, installing, and touching the protective board.
 3. The charging port can withstand up to the specified DC voltage. Chargers above this voltage cannot guarantee that the protection board will not be damaged. Please use the charger within this specification. It is best to choose a charger with a trickle-off function at the end of the charging current. In this way, double insurance is achieved. Chargers that do not have the trickle shutdown function are designed for lead-acid batteries and are not compatible with lithium batteries.
 4. Pay attention to the lead head during use, Do not touch the components on the circuit board with the soldering iron, tin slag, etc., otherwise the protection board may be damaged.
 5. The maximum discharge current is the maximum current that lasts for a few seconds, During the test, the unsustainable time is too long to avoid overheating and damage to the power MOS.
 6. When assembling the protective board and the battery pack, do not put the heat sink aluminum plate close to the surface of the battery cell. Otherwise, heat will be transferred to the battery cell, affecting the safety of the battery pack.
 7. If there is any abnormality during use, please stop using it immediately and return it to the original factory or ask professional maintenance personnel for repair.
 8. If it is a split port protection board, it is forbidden to use P- as a charging port, because when P- is used as a charging port, the battery pack has no overcharge protection. It is forbidden to use C- as a discharge port when the port is split
 9. This protection board has done a lot of reliability tests, and the reliability is much higher than that of the general protection boards on the market. The technology of the battery core must also be guaranteed at the same time to reduce the occurrence of combustion as much as possible.
 10. This protection board is not equipped with a 0V battery charging function. Once the battery is 0V, the battery performance will be severely degraded and may even be damaged.
 11. In order not to damage the battery, the user needs to recharge the battery regularly when it is not in use for a long time (the capacity of the battery pack is more than 2AH, and the storage is longer than 3 months); and after the battery is discharged during use, it must be charged in time within 12 hours to prevent The battery is discharged to 0V due to self-consumption. The customer is required to have an obvious mark on the battery shell for regular maintenance of the battery.
 12. This protection board does not have a reverse charging protection function. If the charger's polarity is reversed, the protection board may be damaged.

Safety Precautions:

The company is committed to quality, Reliability is improved, but generally speaking, electrical parts will have a certain probability of failure. The use environment and conditions will have different durability. The use of lengthy design can avoid abnormal heat and heat caused by overload. Smoke, even personal accidents, fire accidents, social damages, etc. occur.

JBD-AP20S003	Specification: Protection circuit module	
	Page:13 Total:13	Date:12/17/2021

10. Document revision history

date	Draw up	Audit	Modify content
2020-09-22	Wang Ligang	Zhang Qiaoqiao	First release
2020-11-5	Wang Ligang	Zhang Qiaoqiao	The relay is changed from 300A to 500A, and the size is changed from 188*118*46 to 165*114.5*76